

MAGNA3 50-60 F (N)

1 x 230 V, 50/60 Hz

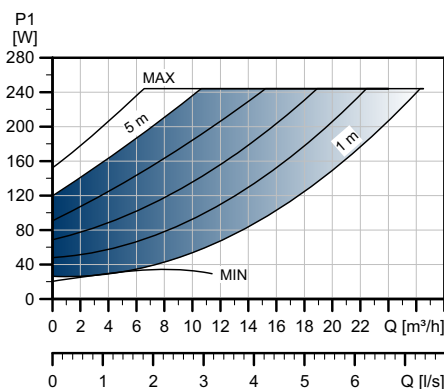
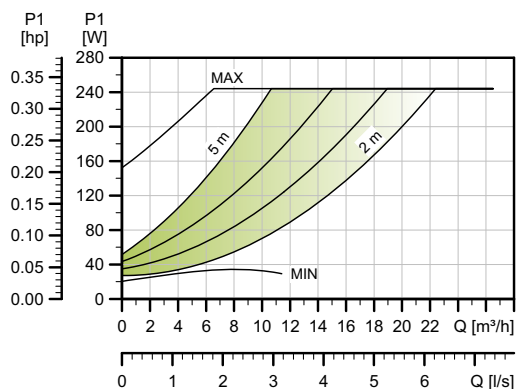
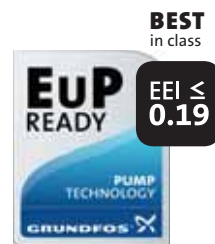
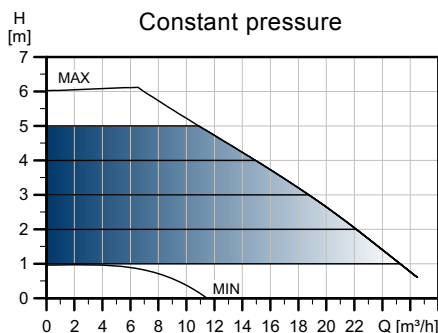
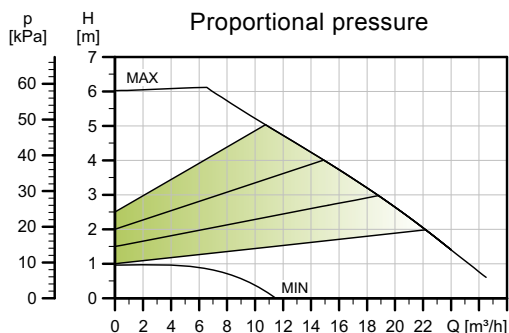

TM05 3740 1912

Speed	P1 [W]	I _{1/1} [A]
Min.	21	0.23
Max.	249	1.13

The pump incorporates overload protection.

Connections: See *Counter flanges*, page 100.
 System pressure: Max. 1.0 MPa (10 bar). Also available as max. 1.6 MPa (16 bar).
 Liquid temperature: -10 °C to +110 °C (TF 110).
 Also available with: Stainless-steel pump housing, type N.
 Specific EEI: 0.19.

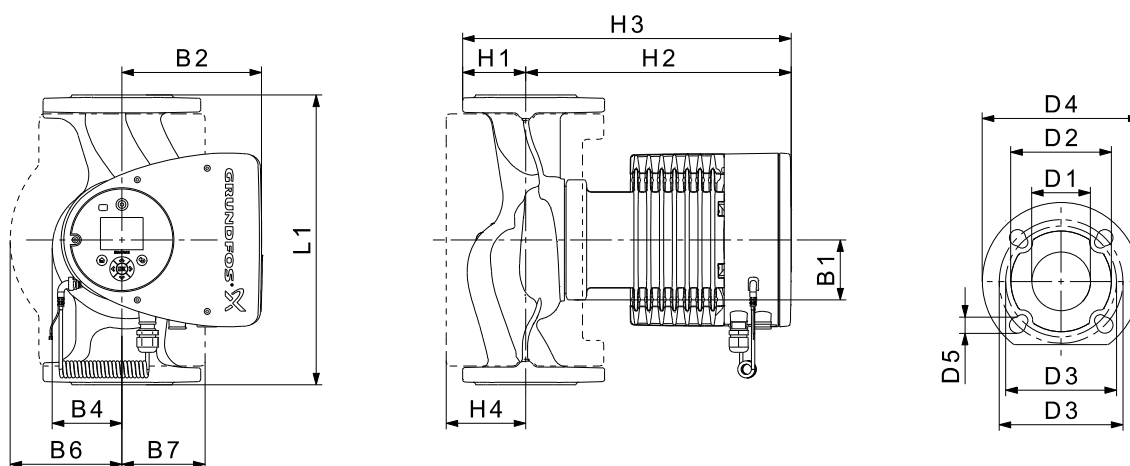

TM05 2204 0312

Pump type	Dimensions [mm]														Weights [kg]		Ship. vol. [m ³]	
	L1	G	B1	B2	B4	B6	H1	H2	H3	H4	D1	D2	D3	D4	D5	Net		Gross
MAGNA3 50-60 F (N)	240	203.9	83.6	164	72.3	127	70.5	303.6	374.1	87	53	102	110/125	165	14/19	17.0	20.4	0.05

For product numbers, see page 95.